

Utile

Carlos Tíscar



EN

Utile is an auxiliary table on which you can place small items so that they are always at hand. Its special cantilever structure also allows it to integrate into the sofa in such a way that its working surface is at the right distance for the greatest user convenience.

SP

Utile, como su propio nombre indica, es una mesita auxiliar que resuelve la necesidad de disponer pequeños objetos para que estén siempre a mano. Su particular estructura en voladizo le permite además adentrarse en el sofá de manera que su plano de servicio quede a la distancia adecuada para mayor comodidad del usuario.

FR

Utile, comme son nom l'indique, est une table d'appoint qui résout la nécessité de disposer de petits objets pour qu'ils soient toujours à portée de main. Sa particulière structure en porte-à-faux lui permet en outre d'aller sur le canapé de telle sorte que son plan de service soit à la distance appropriée pour plus de confort de l'utilisateur.

DE

Wie der Name "Utile" bereits erahnen lässt, handelt es sich um ein sehr facettenreiches Möbelstück zur Platzierung von kleineren Objekten, die man schnell zur Hand haben muss. Seine besondere Form ermöglicht es auch, dass sich die Ablagefläche bequem über das Sofa führen lässt, sodass die Objekte für den Benutzer leicht zu erreichen sind.

RU

Utile это вспомогательный столик, на котором можно разместить небольшие предметы так, чтобы они всегда были под рукой. Его особая консольная структура также позволяет ему интегрироваться в диван таким образом, что его рабочая поверхность находится на правильном расстоянии для наибольшего удобства пользователя.

DIMENSIONS:

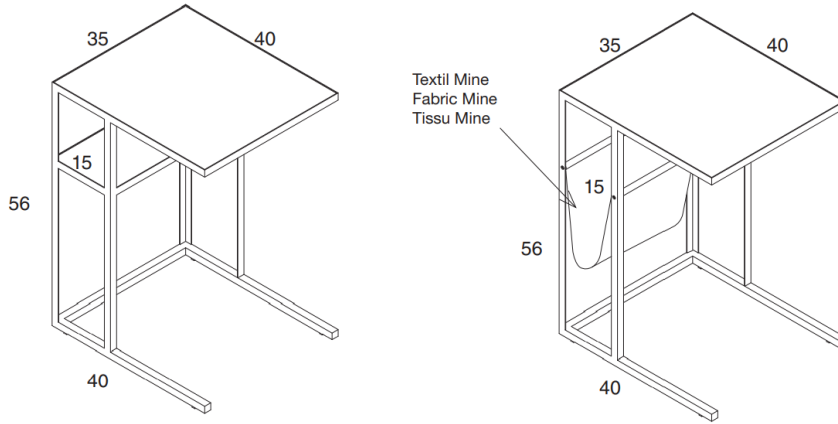

FINISHES:

Lacquers



Natural Veneers



European oak / Roble europeo / Chêne Européen



Leopard oak / Roble Leopard / Chêne Leopard



American walnut / Nogal Americano / Noyer Américain



Smoky oak / Roble Fumé / Chêne Fumé

Ceramics



Hydra Argen



Blaze Dark



Kalos Bianco



Ferox



Concerto

Textiles



Mine Antracita

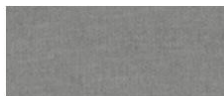

Mine Dolphin



Mine Hunter



Mine Khaki

METAL STRUCTURE

Lacquers



White Epoxi



Black Epoxi



Coffee

Lacquers



White / Blanco / Blanc



Pearl grey / Gris Perla / Gris Perle



Foggy



Rain



Slate / Pizarra / Ardoise



Stone / Piedra / Stone



Sahara



Mocca



Mink / Visón / Vison



Gold



Terracota / Terre Cuite



Brick



Merlot



Taupe



Black / Negro / Noir



Moss



Salvia



Whale blue / Azul Ballena /
Bleu Baleine



Mustard / Mostaza / Moutarde



Navy



Coffee

DESIGNER:

Carlos Tiscar



EN

Carlos Tiscar (1964) finished his studies in 1982 and he currently holds a degree in industrial design from the School of Applied Arts in Valencia, major in industrial design. Two years later, he moved to Italy and graduated from the Scuola Politecnica di Design di Milano. His professional career started in 1987 as a member of the industrial design group Factoria and, later on, as a partner of the consulting firm Gesto Design Management, in 1991.

In 1993, he founded his own studio, Tiscar Design, and his field of expertise is home, office and contract furniture, as well as urban furniture and homeware. Alongside with his studio, he has been a professor in several institutions and schools, such as Barreira (Valencia), AIMME (Paterna) and eset CEU (Alfara del Patriarca). Moreover, he's the former vicepresident of the ADCV (the Designers of the Valencian

SP

Carlos Tiscar 1964. Miembro de ADCV. Aunque en realidad empezó a diseñar a los seis años de edad, tuvo que cursar estudios y graduarse en la Escuela de Artes Aplicadas de Valencia (1982), en la especialidad de Diseño Industrial. Dos años después, se trasladó a Italia para estudiar en la Scuola Politécnica di Design de Milán. Comenzó a dedicarse profesionalmente al diseño como miembro del grupo Factoria Diseño Industrial (1987) y como socio de Gesto Design Management (1991). Desde 1993 dirige su propio estudio.

Ha impartido la asignatura de proyectos para las siguientes escuelas e instituciones: Barreira (Valencia), AIMME (Paterna), eset CEU (Alfara del Patriarca) y EASD (Valencia). Fue presidente de la ADCV (Asociación de Diseñadores de la

FR

Carlos Tiscar 1964, membre du ADCV. Même si en réalité il commence à faire du design à l'âge de 6 ans, il a du suivre des études et se diplômer en Design Industriel à l'Ecole des Beaux Arts de Valence (1982). Deux ans après il se déplace en Italie pour étudier à la Scuola Politécnica di Design à Milan. Il se consacre professionnellement au Design comme membre du Groupe Factoria Design Industrial (1987) et comme partenaire de Gesto Design Management (1991).

Depuis 1993 il dirige sa propre agence de design. Il assure la formation de projets pour les suivantes écoles et établissements: Barreira (Valence), AIMME (Paterna) eset CEU (Alfara del Patriarca) y EASD (Valence). Il a été Président de ADCV (Association de Designers de la communauté Valencienne) de 2012 à 2015. Son travail à remporté

DE

Carlos Tiscar 1964. Mitglied im Verband der Designer der Autonomen Region von Valencia ADCV.

Obwohl er eigentlich schon im Alter von sechs Jahren mit dem Designen begann, musste er in der Schule für angewandte Kunst in Valencia im Fachbereich Industriedesign studieren und einen Abschluss machen (1982). Zwei Jahre später zog er nach Italien um in Mailand an der Polytechnischen Schule für Design (Scuola Politecnica di Design) zu studieren. Als Mitglied der Gruppe Factoria Diseño Industrial (1987) und als Partner von Gesto Design Management (1991) begann er sich professionell dem Design zu widmen.

Seit 1993 leitet er sein eigenes Studio. Er unterrichtete das Fach „Projekte“ an folgenden Schulen und Institutionen: Barreira (Valencia), AIMME (Paterna), eset CEU (Alfara del Patriarca) und EASD (Valencia).

RU

Карлос Тискар, 1964. Член ADCV.

Он начал проектировать еще в возрасте шести лет, затем он учился и закончил школу прикладного искусства Валенсии (1982) по специальности Промышленный Дизайн. Два года спустя он переехал в Италию для учебы в Миланском политехническом университете. Он начал профессионально заниматься дизайном в качестве члена группы промышленного дизайна (1987) и в качестве партнера в Gesto Design Management (1991).

С 1993 года возглавляет собственную студию. Он преподавал проектирование для следующих школ и учреждений: Barreira (Валенсия), AIMME (Патерна), eset CEU (Альфара-дель-Патриарка) и EASD (Валенсия). Он был президентом ADCV (Ассоциация дизайнеров Валенсии) с 2012 по 2015 год. Его заслуги были отмечены, среди прочего, премией Impiva, золотой премией ADCV,

Community Association)

Comunidad Valenciana) de 2012 a 2015. Su trabajo ha merecido, entre otros, el Premio Impiva, el Premio ADCV Oro, el Good Design Award, el German Design Award, y el iF Design Award.

entre d' autres prix , le prix Impiva, le prix ADCV Or, le Good Design Award, Le German Design Award et le IF Design Award.

Von 2012 bis 2015 war er Präsident des ADCV (Verband der Designer der Autonomen Region von Valencia). Für seine Arbeiten erhielt er unter anderem den Impiva Award, den ADCV Gold Award, den Good Design Award, den German Design Award und den iF Design Award.

Good Design Award, German Design Award и iF Design Award.