

PUNTA
Technical Information

nomon
JEWELRY FOR HOME

PUNTA

Technical Information

nomon
JEWELRY FOR HOME

TECHNICAL DRAWINGS

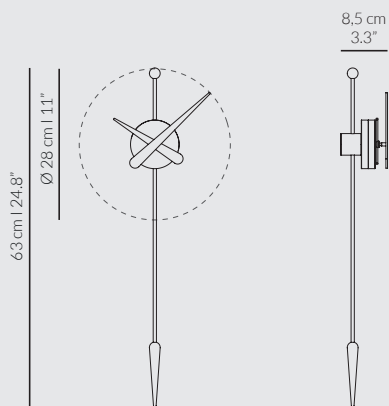

MATERIALS

BOX / CAJA

White or black polystyrene / *Poliestireno negro o blanco*

HANDS / AGUJAS

Walnut wood or oak finished wood / *Madera de nogal o acabado roble*

PENDULUM / PÉNDULO

Walnut wood or oak finished wood / *Madera de nogal o acabado roble*

MECHANISM / MECANISMO

UTS German / *UTS alemán*

PUNTA

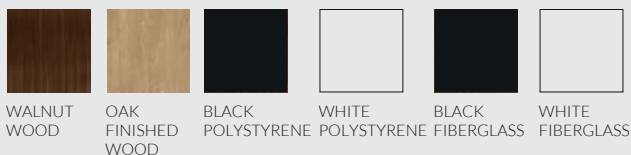

PACKAGING

Weight / *Peso*: 0.35 Kg | 0,35 Kg

Net weight / *Peso neto*: 0.65 Kg | 0,65 Kg

Volumetric weight / *Peso volumétrico*: 0.92 Kg | 0,92 Kg

Dimensions / *Dimensiones*: 4.5" x 26.4" x 2.4" | 11,5cm x 67cm x 6cm

